

MARCH 2023 NEWSLETTER



3月

English Version



✧ Nighttime Consultation for the payment of water bills ✧

- **When:** March 7 (Tue), 17:15 – 20:00
- **Where:** Water Service Division on the 1st floor of the Water Works Department building
- **Contact:** ☎055-934-4853 Water Service Division (*Suido Service ka*)

✧ Change of location for applying for pool usage subsidy tickets ✧

- **What:** Since the City Gymnasium was closed from February 28, please apply for the usage subsidy tickets for the indoor heated swimming pool from March 1 by mail or directly from the With Sport Division on the 8th floor of the city hall.

*For details on how to apply, please visit the city website.

- **Contact:** ☎055-934-4875 With Sports Division (*With Sports ka*)

✧ Information on City Library Closure ✧

- **What:** The library will be closed during the following period for book check.
- **When:** Heda library – March 1 (Wed)
City library – March 6 (Mon) – March 9 (Thu)

* If you are returning books during the period, please put books in the drop box. Videos, DVDs, CDs and picture-story shows (*Kamishibai*) should be returned directly to the library during opening hours, not in in the drop box.

- **Contact:** ☎055-952-1234 City Library (*Shiritsu Toshokan*)
☎0558-94-4420 Heda Library (*Heda Toshokan*)

✧ Receipt of Special Child-Rearing Allowance (*Tokubetsu Jido Fuyo Teate*), Welfare Allowance for Disabled Children (*Shogaiji Fukushi Teate*), and Special Disability Allowance (*Tokubetsu Shogaisha Teate*) ✧

- **What:** There are allowances that can be received by people with a certain level or more of disabilities or those raising people with disabilities. Based on the application, it will be paid out from the month following the application date if it is approved.

*For details such as payout requirements, please contact us or visit the city website.

- **Apply/Contact:** ☎055-934-4829 / Fax: 055-934-2631 Disability Welfare Division (*Shogai Fukushi ka*)

✧ Closure of the Koryo parking lot ✧

- **What:** The Koryo parking lot at the Cultural Centre (*Bunka Centre*) was closed from February 28. Please use the Kanuki parking from March.

- **Apply/Contact:** ☎055-934-4812 Cultural Promotion Division (*Bunka Shinko ka*)

✧ Procedures when moving ✧

Report your change of address within 14 days after moving. The contents will be registered in the Basic Resident Registration System and become valuable data which proves your address. Don't forget to write the full name of the apartment. Things to bring other than your ID are as follows.

Please report your change of address within 14 days after moving!		
Kind of registration	Document required	Period of notification
Tennyu Moving into Numazu	<ul style="list-style-type: none"> ▪ Certificate of moving out (<i>Tenshutsu Shomei sho</i>) ▪ Residence Card (if you are foreigner) ▪ MyNumber Card and Basic Resident Registration Card (if you have) 	Within 14 days from the day you moved in
Tenshutsu Moving out of Numazu	<ul style="list-style-type: none"> ▪ National Health Insurance Card (if you have) ▪ Seal Registration Card (<i>Inkan Toroku Sho</i>) ▪ Insurance Card for the Elderly (applicable persons only) ▪ Long-Term Nursing Care Insurance Card (people aged 65 or older) 	Within 14 days before or after the moving date
Tenkyo Moving within Numazu	<ul style="list-style-type: none"> ▪ National Health Insurance Card (if you have) ▪ Insurance Card for the Elderly (applicable persons only) ▪ Long-Term Nursing Care Insurance Card (people aged 65 or older) ▪ Residence Card (if you are foreigner) ▪ MyNumber Card and Basic Resident Registration Card (if you have) 	Within 14 days from the date you move
Joining or withdrawal from National Health Insurance & National Pension	<ul style="list-style-type: none"> ▪ Certificate of joining or withdrawing from Social Insurance ▪ National Health Insurance Card (if you have) ▪ National Pension Book ▪ Residence Card (if you are foreigner) 	As soon as possible

■ Identity verification required

To prevent false registration by another person, we check each person who comes to register the change of address, or family register (paternal acknowledgement, marriage, divorce, adoption, dissolution of familial relationship). When a proxy submits the registration, the letter of attorney is necessary.

Identification documents: A photo ID card issued by the government or other public offices such as driver's license, passport, MyNumber card, basic resident registration card which has photo.

* In the case of reporting moving in/out and certificate issuance, any two of the following are acceptable.

National Health Insurance Card, National Pension Book, Employee ID Card, Student ID Card and Bankbook

■ Please prepare these documents when you come to apply for the following certificates.

- Certificate of All Records of Koseki (Certificate of Family Register) 戸籍の全部(個人)事項証明書

- Identification

* A letter of attorney is required if an applicant is not a lineal relative.

- Residence Certificate 住民票

- Identification

* A letter of attorney is required if an applicant is not in the same household.

- Seal Registration Certificate 印鑑登録証明書
 - Seal Registration Card (印鑑登録証) or Citizen Card with Seal Confirmation (市民カード)

Notifications of births, deaths, and changes of address are required by law.

■ You can process a moving-out notification online.

From February 6, reporting moving-out can be accepted online using Mynportal. If you use this service, you do not need to visit the Numazu City Hall in principle when moving out. This service is for people who have MyNumber Card with a valid electronic certificate and moving out within Japan. In addition to moving out only yourself, you can also use it for moving with members of the same household or members of the same household other than yourself.

* After submitting a moving-out notification using Mynportal, you will need to complete movin-in procedures at the counter of your new municipality.

- **Contact:** ☎055-934-4720 Citizens' Division (*Shimin ka*)

Other Procedures

◎Water Service

【When you start using】 Please fill in the “Water Use Starting Application (水道使用開始申込書)” (post card) and submit it before using. If you cannot find the postcard, please inquire at the division in charge.

【When you stop using】 Please contact us at least three days before the last day you intend to use the water service.

- **Contact:** ☎055-934-4853 Water Service Division (*Suido Service ka*)

In addition, please do not forget to check the procedures related to moving, such as electricity, gas, telephone, and mail.

----- We make a holiday window for moving season! -----

Holiday counters are less crowded than weekdays, and procedures are relatively smooth. If it is difficult for you to come to the office on weekdays due to work, etc., please visit us during the following period.

When: March 26 (Sun) and April 2 (Sun)

Time: 8:30 – 17:15

Place: Citizens' Division, 1st floor at City Hall *Not available at satellite windows

Services available

1. Change of address (Moving in, out, and relocation within Numazu, etc.)
2. Submission of registration documents (Marriage, divorce, birth, death, etc.)
3. Issuance of various certificates (Resident certificate, family registry and tax certificate etc.)

*Some tax certificates cannot be issued.

**Koiki Madoguchi Service (広域窓口サービス)* (for Sunzu area) will not be available.

4. Seal registration and issuance of seal registration certificate
5. Issuance of temporary license (*Kari Number*)

6. Joining or withdrawal from the national health insurance and national pension system
7. Reissue of the national health insurance card
8. Issuance of a passport (Receiving only. You cannot apply.)
9. Issuance of “MyNumber card” (reservation based)

*Please contact us at least 5 days prior to the date of the holiday window.

- **Contact:** ☎055-934-4721 Citizens' Division (*Shimin ka*)

----- Introducing useful service counters -----

Services at city hall satellite windows

Eleven City Hall satellite windows can issue certificates or registration documents.

Time: 8:30 – 17:15 (Weekday only) * Holiday windows will be not be opened.

<p>Services available</p> <ol style="list-style-type: none"> 1. Change of address (Moving in, out, and relocation in Numazu, etc.) 2. Submission of registration documents (Marriage, divorce, birth, death, etc.) 3. Issuance of various certificates (Resident certificate, family registry and tax certificate etc.) 4. Seal registration and issuance of seal registration certificate 5. Issuance of MyNumber card etc. 6. Joining or withdrawal from the national health insurance and national pension system 7. Reissue of the national health insurance card 8. Acceptance of application for funeral expenses etc. 	Satellite window	Address	Phone Number
	Ooka	Ooka 2357-1	055-921-2085
	Kanaoka	Ebaracho 3-1	055-921-2084
	Katahama	Ozuwa 46-1	055-962-2083
	Ashitaka	Higashibara 358-1	055-966-2490
	Hara	Hara 1200-3	055-966-1001
	Ukishima	Hiranuma 375-1	055-966-2009
	Shizuura	Shishihama 34	055-931-3004
	Uchiura	Uchiura Mito 249-3	055-943-2044
	Nishiura	NishiuraTachibo 22-1	055-942-2002
	Ohira	Ohira 2197-1	055-934-3290
Heda	Heda 1294-3	0558-94-3111	

Certificate Issuance Service at convenience stores

Various certificates can be issued at multi-copy machines located in convenience stores all around Japan. To use this service, MyNumber card is required.

Type of certificate	Time	Subject	Cost
Residence Certificate (<i>Jumin hyo</i>)	6:30 – 23:00 (End and beginning of a year are excluded)	Certificate with current address (Resident register code can't be printed.)	¥200
Seal Registration Certificate (<i>Inkan Toroku Shomei</i>)		People who have a seal registered	¥200
Family Register Certificate (<i>Koseki</i>)		Current certificate for the person whose permanent address and current address are in Numazu.	¥350
Tax Certificate (latest fiscal year's only)		Certificate only for the person themselves who has taxation information in Numazu	¥200

* Due to system maintenance, issuance services of certificates through a convenience store and Raku-Raku application service is suspended all day on March 8.

* The service cannot be used with a notification card, basic resident register card, or citizen card.

* Those who did not wish to have an electronic certificate issued when applying for and receiving a MyNumber Card cannot use this service.

Service for non-Numazu city residents

Certificates can also be issued mutually among the 12 cities and towns in the Sunzu area (Numazu City, Atami City, Mishima City, Ito City, Gotenba City, Susono City, Izu City, Izunokuni City, Kannami Town, Shimizu Town, Nagaizumi Town and Oyama Town)
Time: 8:30 – 17:00 (weekday only)

Services available

1. Issuance of Residence Certificate
2. Issuance of Seal Registration Certificate
3. Issuance of Certificate of All Records of *Koseki* (Certificate of Family Register)

Person who can use the services for issuing residence certificates and seal registration certificates are the person themselves or a person who is registered in the same household. Persons who can use the Family Register Certificate issuance service are those who have a resident registration and permanent domicile in the 12 cities/towns in the Sunzu area. Please contact a City/Town Office at each municipality for details.
 *A residence certificate without a registered domicile (本籍) can be issued in any municipality nationwide using the Basic Resident Register network.

- **Contact:** ☎ 055-934-4720 Citizens' Division (*Shimin ka*)

✧ Assistance in Mynapoints Application ✧

- **What:** For those who do not have access to a smartphone when applying for Mynapoint, application assistance is available outside the main city hall.

Where	When	Where	When
Kanaoka Chiku Center	March 2 (Thu), 7 (Tue), 8 (Wed), 9 (Thu), 23 (Thu), 28 (Tue), 29 (Wed)	Uchiura Chiku Center	March 15 (Wed)
Ooka Chiku Center	March 19 (Sun), 26 (Sun)	Nishiura Chiku Center	March 3 (Fri)
Ashitaka Chiku Center	March 1 (Wed), 5 (Sun), 15 (Wed), 18 (Sat)	Hara Chiku Center	March 10 (Fri), 14 (Tue), 17 (Fri), 24 (Fri), 30 (Thu), 31 (Fri)
Katahama Chiku Center	March 12 (Sun), 21 (Holiday), 25 (Sat)	Ukishima Chiku Center	March 3 (Fri), 18 (Sat), 25 (Sat)
Oohirachi Chiku Center	March 4 (Sat), 5 (Sun), 21 (Holiday)	Heda Chiku Center	March 16 (Thu)
Shizukaura Chiku Center	March 1 (Wed), 4 (Sat), 12 (Sun), 16 (Thu)		

When: 10:00 - 16:00

- **Things to Bring:**

- ① MyNumber card
- ② The 4 digit PIN number
- ③ Something that can give information of the bank account in the name of the person (such as a bankbook)
- ④ E-money card or other services that are eligible for points.

* It may require waiting due to the congestion.

* For ③, it is only necessary for people who will register their bank accounts to receive the public money.

Please check the website for eligible services for receiving Mynapoints.

- **Contact:** ☎ 055-934-2569 ICT Promotion Division (*ICT Suishin ka*)



Website

✧ Health Center Information ✧

- **What:** Extension of the deadline for Claiming Hepatitis C Benefits
- **Who:** People who have been infected with the hepatitis C virus through certain blood products can file a lawsuit against the government and receive benefits upon settlement. Due to a revision of the law, the deadline for claiming benefits has been extended to January 17, 2028. In addition, the benefit amount for those who have died as a result of contracting fulminant hepatitis has been increased, so please contact us for more information.

Contact: ☎ 0120-509-002 Ministry of Health, Labor and Welfare Consultation Service for Fibrinogen Products/☎ 054-221-2869 Pharmaceutical Affairs Division, Department of Health and Welfare, Consumer Health Bureau, Prefectural Government/☎ 055-951-3480 Health Promotion Division (*Kenko Zukuri ka*)

✧ Holiday/Nighttime consulting window for national health insurance payment ✧

- **When:** March 12 (Sun) 9:00 - 12:00 / March 7 (Tue), 22 (Wed) 17:15 - 19:00
- **Where:** National Health Insurance Division, 1st floor, City Hall
- **Contact:** ☎055-934-4727 National Health Insurance Division (*Kokumin Kenko Hoken ka*)

✧ The announcement of Reiwa 5 small car tax (based on classification) ✧

Small car tax is imposed on the owner on April 1 every year. There is no monthly refund system even if you scrap a car or change the owner on or after April 2. Please complete the application of handing over, disposal or loss of motor bikes and small cars by the end of March.

- **Contact:** ☎ 055-934-4734 Municipal Tax Division (*Shimin Zei ka*)

✧ Please be careful with PM2.5! ✧

♣ What is PM2.5?

It is a tiny particle smaller than 2.5 micrometers, floating in the atmosphere that can be absorbed into the lungs.

*1 micrometer is equal to 1/1000 mm.

♣ Things to be careful when the warning is issued:

If alert information is announced by the prefecture, we will inform it via PA system etc. those who have respiratory/circulatory diseases etc., children and elderly should be particularly careful. Please follow the suggested measures below:

- Refrain from going out when it's not necessary
- Refrain from doing outside activities
- Wear a mask that's particularly designed to counter virus of smaller particles

♣ Observation system in Shizuoka prefecture:

24 hours observation is conducted in 38 places within the prefecture. The collected data and prediction information are available on the Shizuoka Atmosphere Observation System (静岡県大気常時監視システム).

* Please check the details on the city website.

- **Contact:** ☎055-934-4740 Environment Policy Division (*Kankyo Seisaku ka*)

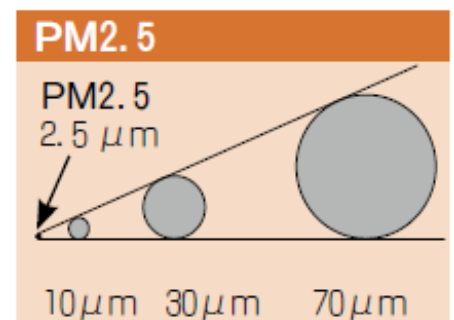

✧ Have good manners and keep our city clean ✧

- **Please stop littering:** To maintain a good living environment, the city, based on “Regulations to keep Numazu city clean”, prohibits littering of trash and cigarette butts and the leaving of dogs’ mess in public places as well as conducting awareness-raising activities with local environmental beautification instructors.
- **Please follow smoking rules:** Busy areas around Numazu station have been designated as “Non-smoking areas” based on “Regulations regarding street smoking in Numazu City”. In addition to the regulated area, we ask for your cooperation to refrain from smoking in streets and public areas such as parks.
- **Contact:** ☎055-934-4743 Environmental Policy Division (*Kankyo Seisaku Ka*)

✧ Childcare Support Fund Interest Supply System for Workers ✧

- **What:** The city will subsidize the interest for the salary workers living in the city to use the childcare support fund of the Shizuoka Labor Bank.

Use of fund	Childcare cost for preschool children
Interest subsidy limit	1,000,000 yen per household (2,000,000 yen if there are two or more children)
Interest rate	Within 2.0% per year (for 5 years)

- **Who:**
 1. Father or mother who has a child/children from fetus to before elementary school age. (Proof required)
 2. A person who have lived in the city for over a year, and have paid the city tax in full.
 3. A person who are using the “Welfare Loan (child-rearing support loan)” of the labor bank
- **When:** In addition to weekly business hours (9:00 - 15:00), we also hold consultation meetings on Wednesdays (17:00 - 19:00) and Sundays (9:00 - 12:00, 13:00 - 16:00). Reservation is required. Please contact us for more details on how to apply.
- **Apply/Contact:** ☎055-926-5515 Roukin Numazu Loan Centre
- **Contact:** ☎055-934-4749 Commerce and Industry Promotion division (*Shoko Shinko ka*)

✧ Spring National fire prevention campaign ✧

- **What:** From March 1 (Wed) to 7 (Tue), the Spring National fire prevention campaign will be held. We should always be aware of fire and aim to live safely and securely.

10 points to prevent fire

4 Practices

- ① Do not smoke while laying down.
- ② Use stoves where there are no combustible objects in the area.
- ③ Always turn off the gas stove when going away from the stove.
- ④ Clean sockets and remove unnecessary plugs.

6 measures

- ① Use equipment with a safety device for stoves, gas stoves, etc.
- ② Regularly check residential fire alarms and replace them every 10 years.
- ③ Keep rooms tidy and use flameproofing products for bed clothes, clothing and curtains to avoid fire.
- ④ Install a fire extinguisher and check how to use it.
- ⑤ Elderly people and people with disabilities should always secure and prepare evacuation routes and evacuation methods.
- ⑥ Take for prevention measures throughout the region by participating in fire prevention training and individual visits.

- **Contact:** ☎ 055-935-5119 Suntou-Izu Firefighting Headquarters

Information on the vaccination of COVID-19

Infants, children, and those 12 years and older can be vaccinated at medical institutions in the city. Prior reservation is necessary for vaccination.

- ◆ Reservation and consultation for vaccination: ☎ 0120-236-258 (toll-free)
8:30 am – 6 pm (Also available on Saturdays, Sundays and national holidays)
- ◆ COVID-19 Vaccination Office: ☎ 055-951-3588; Weekdays, 8:30 am - 5 pm



For detail

Information on COVID-19 Infections

- ◆ City Consultation Desk
Crisis Management Division (*Kiki Kanri ka*) ☎ 055-934-4803 ☎ 055-934-4758
(weekdays, 8:30 am - 5:15 pm)
- ◆ Prefectural consultation centre for fever, etc.
*People who do not have a family doctor and have a fever, fatigue etc.
☎ 050-5371-0561 (open 24/7)
☎ 050-5371-0562 (weekdays, 8:30am - 5:15pm)

❖ Please note that the information is subject to change due to COVID-19. Please contact the organizers of the event or check for event cancellation and postponement information on the city website.

DISCLAIMER: The English version is a translation of the original newsletters in Japanese. While reasonable efforts are made to provide accurate translations, there might be some discrepancy. We encourage you to please report if you find any inaccuracy or translation error.